

Power ARC 180 LT



GeKaMac[®]



Power ARC 180 LT **Manual Instructions**

Please Read and Understand This Manual
Before Operating Welding Machine

www.gedikwelding.com

This machine is for internal use only.

It complies with the WEEE Directive.

This machine has been designed in accordance with the EN 60974-1 and EN 60974-10 standards.

The machine is safe when installation, operation, and maintenance are performed in accordance with the user manual and regulations. The operator and machine owner are responsible for adhering to safety rules.

Gedik Kaynak San. Ve Tic. A.Ş. assumes no responsibility for safety or CE compliance if any modifications are made to the machine or if safety rules are not followed.



This Class A equipment is not suitable for use in homes and similar residential areas where the power supply is provided by the low-voltage public electricity network.



This machine is not household waste and cannot be disposed of in the trash.

When the machine reaches the end of its service life or becomes obsolete, it must be disposed of in accordance with regulations.

COMPLIES WITH THE WEEE DIRECTIVE.

Eco Design Statement

This machine has been designed and manufactured in accordance with the requirements of the 2009/125/EC Eco Design Directive concerning the environmentally friendly design of energy-related products.

Accordingly, machines with an idle mode are as follows.

	Idle Mode
MMA	X
MIG	√
TIG	√
Plazma	√
SAW	Out of Scope

Efficiency measurements should be conducted only on the power unit. The water cooling system should be disabled. For more information on measurements and machine settings, Gedik Kaynak Sanayi ve Ticaret A.Ş. should be consulted.

**AT UYGUNLUK BEYANI****EU DECLARATION OF CONFORMITY**

Bu uygunluk beyanı yalnızca imalatçının sorumluluğu altında düzenlenir.

This declaration of conformity is issued under the sole responsibility of the manufacturer.

İstanbul, Turkey, 08.03.2024

İmalatçı / Manufacturer

GEDİK KAYNAK SANAYİ ve TİCARET A.Ş.

Ankara Cad. No.306 Seyhli Pendik İSTANBUL TÜRKİYE

Ürün / Product

ARC WELDING MACHINE

Marka-Model / Brand- Model

PoWer ARC 180 LT

Yukarıda tanımlanan beyanın nesnesi ilgili uyumlaştırılmış AB mevzuatı ile uyumludur.

The object of the declaration described above, is in conformity with the relevant union harmonisation legislation.

Direktifler / Directives

2014/30/EU & 2014/35/EU & 2009/125/EC

Uyumlaştırılmış standartlar ve uygunluğun deklare edilmesiyle ilişkili diğer referanslar.

References to the relevant harmonised standards used and references to the other technical specifications in relation to which conformity is declared.

EN IEC 60974-1:2022+A11:2022

EN IEC 60974-10:2021

Bu ekipman, talimatlara uygun kurulduğunda, bakımı yapıldığında ve kullanıldığında belirtilen standartlara uygundur. Makine üzerinde bir değişiklik yapıldığında veya yanlış kullanımda deklarasyon geçersiz olur.

The equipment is in compliance with pertinent legislation when installed, utilized, and maintained in accordance with the enclosed instructions. This declaration will be invalid under any modification or improper use.

İmalatçı Adına imzalayan / Signed for and on behalf of:

Hatice Özel, Equipment Business Unit Director





Attention!

Our Valued Customer,

We kindly request that you obey the warnings mentioned below:

- Definitely have the “Warranty Document” approved when you get the machine.
- Use the machine in a way that is in accordance with the fundamentals that are mentioned in the user’s guide of the machine.
- Refer to the nearest GEDIK WELDING authorized service or the service center of GEDIK WELDING when a problem comes up.



Attention!

Field Evaluation

Before the user installs arc welding equipment, it is necessary to evaluate the working area in terms of the risk of electromagnetic problems. Therefore the following items should be considered.

- Other supply, control, signal and telephone cables above or under the machine and near the welding machine;
- Radio and television transmitters and receivers;
- Computer and other control devices;
- Critical devices, such as the protection of industrial devices, in terms of safety;
- Pacemakers, hearing aids, etc. the health of people that use devices in the vicinity;
- Calibration or measurement devices;
- The associated of all other devices in the area (The user should be careful that other nearby equipment can work together with the arc welding equipment. For this reason additional protection devices may be required);
- The time of day when the welding or other activity was applied.

The area that may be affected, may vary depending on the structure plan of the used machine and the area covered by the other applications and may extend beyond the machine's used construction.

Evaluation of Welding Configuration

In addition to field evaluating, evaluation of the arc weld installation can be used to measure and remove interference conditions. The interference evaluation should include in situ measurements as described at CISPR 11:2009 in paragraph 10. In situ measurements can also be used to verify the efficiency of attenuation measurements.

Thank you for preferring one of GeKaMac[®] products.

GEDİK KAYNAK SAN. VE TİC. A.Ş.
Ankara Caddesi No:306 Şeyhli 34906 Pendik – İstanbul / TÜRKİYE

Tel: +90 216 378 50 00 (pbx)

Fax: +90 216 378 20 44

Web: www.gedikkaynak.com.tr

E-Posta: gedik@gedik.com.tr

1. INDEX

	Page
1. Index	3
2. Environment&Safety Rules	4
2.1. Electrical Shock	4
2.2. Arc Rays.....	4
2.3. Gases and Fumes	4
2.4. Welding Sparks.....	4
2.5. Electricity and Magnetism.....	5
2.6. Accidents Originated From The Moving Parts	5
2.7. Environment	5
3. Electromagnetic Compatibility (EMC).....	6
4. General Informations and Warnings.....	7
5. Advantages and General Properties of Power ARC LT Series	7
6. Technical Informations	8
7. Electrical Principle Drawing.....	8
8. Operational Warnings.....	9
8.1. Installation	9
8.2. Safety	9
9. Layout For Front&Rare Panel	10
10. Maintenance.....	11
11. Troubleshooting	11
12. Warranty Conditions.....	12
13. Warranty Documents	

2. ENVIRONMENT&SAFETY RULES

Protect yourself and others against possible serious injury or death risks. Keep children away. People who have pacemakers in their bodies should consult their doctors before operating the welding machine. Be careful when you are doing operations with your hands on the pieces. Use proper equipment that are necessary to protect yourself from burns that can be caused by excessive heating of the piece during welding and / or cutting operation. Be sure that all set up, maintenance and repair related operations are performed only by qualified people.

2.1. ELECTRICAL SHOCK



Electrode and the piece that is being worked on or ground circuits are active in terms of electricity while the welding machine is on. Don't touch these active parts with bare hands or wet clothing. Wear dry gloves that have no holes to insulate your hands.

2.2. ARC RAYS



Use a protective mask with a proper filter to protect your eyes from the sparks and the rays of the arc while welding or watching such an activity. The head mask and the filtered glasses must meet the ANSI Z87.1 standards

2.3. GASES AND FUMES



Fumes and gases that are harmful to health can form during the welding operation. Do not inhale these gases or fumes. Keep your head out of the fumes while welding. Provide sufficient ventilation in the arc and / or use fume suction machines to keep fumes and gases out of the breathing area

2.4. WELDING SPARKS



Put away elements that are fire hazards from the welding area. If this is not possible, cover these hazards to prevent welding sparks from starting a fire. Do not forget that welding sparks and hot materials coming from welding can go on to neighboring areas easily through small cracks and openings. Don't do welding near hydraulic lines. Always keep a fire extinguisher on hand.

2.5. ELECTRICITY AND MAGNETISM



Electric flow that passes through a conductor causes Electric and Magnetic Fields (EMF) to be formed. Welding current creates EMF around welding cables and welding machines.

— EMF can ruin the operation of some pacemakers. For this reason, welders who have pacemakers in their bodies should consult their doctors before welding.

— Being exposed to EMF during welding, can cause other unknown health problems.

— Getting exposed to EMF will be minimized by paying attention to the following instructions:

- Guide electrode and chassis cables together.
- Never wrap electrode and chassis cables around your body.
- Do not place your body between the electrode and chassis cables.
- Connect the chassis cable as close to the piece that is being worked on as possible.
- Stay as far away as you can from the power units.

2.6. ACCIDENTS ORIGINATED FROM THE MOVING PARTS

- Stay away from moving objects.
- Be careful while working next to moving parts.
- Choose metal-nosed shoes against the falling.
- Keep the machine covers closed.

2.7. ENVIRONMENT



Suitable for AEEE regulation.

3. ELECTROMAGNETIC COMPATIBILITY (EMC)

This machine has been designed in accordance with all related regulations and norms. Additionally, it can still generate electromagnetic forces that affect other systems such as communications (telephone, radio, television). These affects can cause security problems in the exposed systems. Read carefully and understand this section in order to reduce or get rid of the affects that can be created by this machine.

This machine has been designed to be operated in the industry area. If it is operated in private places (house etc.), it will become necessary to take special precautionary measures in order to prevent possible electromagnetic affects. It is necessary for the user to set up and operate these machines just like the way it is described in the handbook. If an electromagnetic affect is perceived due to the operation of these machines, the user should take corrective measures in order to get rid of these affects. If necessary, the user should contact GEDIK WELDING IND. COM. LTD. CO. No changes should be made in the machine without getting written approval from GEDIK WELDING IND. COM. LTD. CO.

The control of the work area should be made in terms of tools that can work improperly due to the electromagnetic affects before the machine is assembled.

- Inlet and outlet cables, telephone cables and control cables that are found in the work area of the machine.
- Radio and/or television transmitters and receivers,
- Computer or computer controlled tools,
- Safety and control equipment for industrial operations,
- Calibration and measurement appliances,
- Medical appliances such as heart rhytme appliance and hearing aids,

Control the electromagnetic immunity of the equipments that operate near the work area. The user should be certain that all the equipments that are in the work place are compatible. Otherwise, it can necessitate additional protective measures.

Ideal dimensions of the work place are determined by the construction of the area and other factors that are found there. Take the warnings below into consideration in order to decrease the affects of the electromagnetic waves that the machine generates:

* Make the connection of the machine with the network electricity in the way it is stated in the user's guide. If an electromagnetic interaction comes into being, such preventive measures as filtering the main electrical inlet may need to be taken.

* Outlet cables should be as short as possible and should be kept together.

4. GENERAL INFORMATIONS AND WARNINGS

Do not set up, operate or repair before reading the user's guide and the security measures that are found in it.

Hide this user's guide and always have it on hand.

- Cut off the electrical connection between the welding machine and the network when the work is finished or when you are going to take a long break.
- Do not make any changes in the welding machine. This operation can cause the machine to lose its properties and a change in technical data.
- It is forbidden to do adaptation on the welding machine. Doing adaptation does not only cause the loss of warranty rights, but also can jeopardize the operational safety of the machine and can create the risk of electrocution for the users.
- A damage in the welding machine due to a mistake of the user will cause the loss of warranty rights.
- Acceptable environmental temperature range during work is between -10 °C and +40 °C.
- Acceptable relative humidity rate is 90% at 20 °C.
- Manufacturing company reserves the right to change the technical properties without prior notice.

5. ADVANTAGES AND GENERAL PROPERTIES OF POWER ARC LT SERIES

Since the 1980s, the size of the welding machines has been reduced and their productivity has increased thanks to the inverter welding machines located in the international market.

ARC LT-series(discrete)welder is a MMA arc welder which adopts the insulated gate bipolar transistor(IGBT)power module.

It can change work frequency to medium frequency so as to replace the traditional hulking work frequency transformer with the cabinet medium frequency transformer.

Thus, it is characterized with portable, small size, light weight, low consumption and noise etc.

ARC LT -series(discrete) has excellent performance: constant current output makes welding arc more stable; fast dynamic response speed reduces the impact from the arc length fluctuation to the current.

There are also some automatic protection functions for under voltage, over current, over heat, etc. inside the welders, when the problems listed before occurred, the alarm on the front panel is light and at the same time the output current will be cut off. It can self-protect and prolong the using life and greatly improved the reliability of the welders.

ARC LT -series can be ignited easily, also with little splash and good weld bead.

ARC LT -series(discrete) is widely used in Petroleum, chemical, mechanical, shipbuilding, architecture, boiler, pressure container, war industry and installation and so on. This machine has high duty cycle even in the 40% which can keep the continuous operation. The frame is Stability of the machine, which can keep working under high temperature and corrosion environment.

The advantages of PoWer ARC LT series welding machine:

- High quality welding and steady arc with constant DC current
- Easy ignition possibility of the electrode
- Light weight and easy portability, simple installation and operation

6. TECHNICAL INFORMATIONS

Models	ARC 160LT	ARC 180LT	ARC 200LT
Power Supply Voltage(V)	1~220/230/240±10%	1~220/230/240±10%	1~220/230/240±10%
Frequency (Hz)	50/60	50/60	50/60
Rated Input Power(kW)	5 MMA/ 3.5 TIG	5.8 MMA/ 4 TIG	6.8 MMA/ 4.3 TIG
Rated Input Current(A)	37 MMA/ 27 TIG	41 MMA/ 31 TIG	46 MMA/ 31 TIG
Duty Cycle(40°C 10 dk)	40% 160A 60% 135A 100% 105A	25% 180A 60% 120A 100% 90A	30% 200A 60% 145A 100% 110A
No Load Voltage(V)	62	59	63
Welding Current Range(A)	10-160	10-180	10-200
Efficiency(%)	≥85%	≥85%	≥85%
Power Factor	0.6	0.6	0.7
Net Weight(Kg)	4.5	4.5	4.5
Protection Class	IP23	IP23	IP23
Insulation Class	H	H	H
Dimensions(mm)	290x135x220	290x135x220	290x135x220
Electrode Diameter	Ø1.6 ~ Ø4.0	Ø1.6 ~ Ø5.0	Ø1.6 ~ Ø5.0
Electrode Type	6013, 7018 etc.	6013, 7018 etc.	6013, 7018 etc.

7. ELECTRICAL PRINCIPLE DRAWING

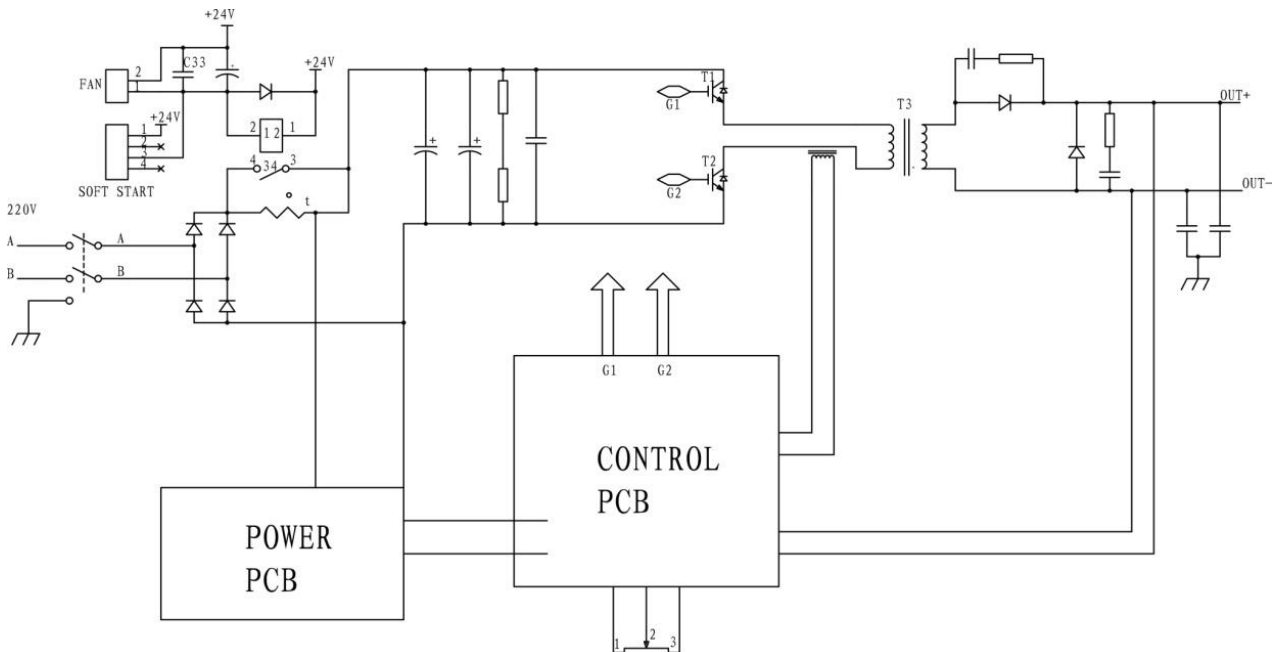

8. OPERATIONAL WARNINGS

8.1 Installation

- (1)Welding environmental temperature should be between -10°C to 40°C .
- (2)Welding should be done in relatively dry environments, the air humidity of not more than 90%.
- (3)to avoid areas containing dust or corrosive gas welding operation environment.
- (4)to avoid sunlight or rain, welding, do not let water or rain water infiltrated the welding machine.
- (5)to avoid the strong air flow environment for gas welding operations.

8.2 Safety

Welding machine has been installed in over-voltage, over current and over temperature protection circuit, when the grid voltage, output current and the internal temperature exceeds the set temperature, the welding machine will automatically stop working; but excessive use will result in welding damage, so you need to note the following:

- (1)To ensure good ventilation!

The welder at work have a greater current flow through the cooling of natural ventilation van not meet the requirements of welding, it is equipped with cooling fans to help the welder. Before using, please check the vents to make sure it has not been blocked or covered the distance between the object and the surrounding welding should not be less than 0.3 meters, welding machines should have been so good ventilation, to ensure the normal operation of welding machine extending welder life.

- (2)Prohibit the overload!

By welding machine operators should ensure that the duty cycle to allow use of welding (see technical data table), keeping the welding current within the normal range, if the current overload will shorten the life of welding machine welding machine and may even burn.

- (3)Prohibits the over-voltage!

Supply voltage listed in the "Technical Data Sheet", the general case, the welding voltage within the circuit will automatically compensate to ensure that the welding current in the permitted range. If the voltage exceeds the allowable value, will damage the welder, the user should be fully aware of this situation, take appropriate preventive measures.

- (4)After each welding machine comes with grounding screw, and marked with ground markers. Before use, use a larger than 2.5mm cable, in the welding chassis ground to discharge any static electricity or to prevent leakage accidents.

- (5)If the welding work over the standard loading time, the welding machine may suddenly stop working into the protected status, which means that the load beyond the standard rate of welding, excessive heat triggered a temperature control switch, the welding machine to stop working, while front panel alarm indicator lights up. In this case , you do not unplug the power plug, to maintain the cooling fan rotation. The red light goes out, the temperature dropped to a reasonable extent, and then you can restart welding.

9. LAYOUT FOR FRONT&REAR PANEL



1. **Positive (+) Welding Cable Connection:** Positive output connection for welding current.
2. **Negative (-) Welding Cable Connection:** Negative output connection for welding current.
3. **Welding Current Control Button:** Set welding current (20 ~200A).
4. **Power Indicator Lamp:** This lamp is activated when the machine is turned on.
5. **Thermic Lamp:** In situations such as high temperatures, machine protection is engaged and the lamp is activated.
6. **Power Switch:** Choose "ON", power through; Choose "OFF", power cut off.
7. **Fan:** Cooling Fan
8. **Cable Clamp:** Fastened the mains cable.
9. **Mode Switch:** choose (left) LIFT TIG; choose (right) MMA

10. MAINTENANCE

In order to guarantee that arc welding machine works high-efficiently and in safety, it must be maintained regularly. Let customers understand the maintenance methods and means of arc welding machine more , enable customers to carry on simple examination and safeguarding by oneself, try one's best to reduce the fault rate and repair times of arc welding machine, so as to lengthen service life of arc welding machine .Maintenance items in detail are in the following table.

• **Warning: For safety while maintaining the machine, please shut off the supply power and wait for 3 minutes, until capacity voltage already drops to safe voltage 36V.**

(1)periodic inspection welding internal circuit connections, make sure connections are correct and reliable connection, (especially the joints or components). If any rust and loose application of sanding off rust layer and the oxide film, reconnect, and tighten.

(2)The machine power, do not allow hands, hair and tools near live components inside the machine, such as: fans, so as not to hurt or cause damage to the machine.

(3)Regularly with a clean dry compressed air to dust the machine, compressed air pressure should be at reasonable levels in order to avoid damage to the welding of small components inside. Dust the machine works well, no dust under normal circumstances (except in exceptional circumstances).

(4)Avoid water or water vapor into the welding machine inside, if there is such a case, the internal welding machine should be dried. Then measured with a mugger insulation of the welding machine(including the connections between nodes and the connection point with the case of companies).Only confirms that no unusual circumstances, can continue to welding work.

(5)Regular inspections for damage the cable insulation, if any, to wrap or replace the cable.

(6)If not using welding machine, welding machine should be back in the box and kept in a dry environment.

11. TROUBLESHOOTING

TROUBLES	SOLUTIONS
Power indicator does not light, fan does not turn, no welding output.	<ol style="list-style-type: none"> 1. Make sure the power switch is turned on. 2. Confirm that the power input cable are connected with electricity.
Fan switch, or not subject to potential instability in the welding current control	<ol style="list-style-type: none"> 1. The current potential is damaged, should be replaced. 2. bad connections, such as plug-in to be checked.
Power indicator light shows the normal fan rotating normal, no welding output.	<ol style="list-style-type: none"> 1. check all connectors inside the machine if there is bad. 2. a circuit output connections or bad. 3. the alarm indicator light <ol style="list-style-type: none"> (1)that access to protected status because of overheating, in which case, To maintain power, so that the temperature dropped to the machine fan Reasonable temperature, until light goes out, you can continue working; (2)Check the thermal switch is damaged
Hot welding clamp	Welding clamp rated current is too small, the replacement of larger size welding clamp.
Manual welding big splash	Output polarity is unreasonable, reversed output connector

12. WARRANTY CONDITIONS

1. The length of the warranty starts on the date of delivery and it is for 1 year.
2. The whole merchandise including all its parts are covered by the warranty of our company.
3. If the merchandise breaks down within the length of the warranty, the time spent in the repair shop will be added to the length of the warranty. The length of repair of the merchandise is at the maximum 20 working days. This period of time starts on the date that the merchandise was delivered at one of the following locations: A service station or the seller of the merchandise or dealer or agency or representation office or importer or manufacturer, in this order if there are no service stations.
4. If the merchandise breaks down either due to material and workmanship or assembly lines within the length of the Warranty, it will be repaired without demanding any money under the name of expenditure of workmanship, the cost of the changed piece or under any other name.
5. Replacement operation will be done without charge in cases where the merchandise repeats the same fault more than twice or different faults come up more than four times within the length of the warranty, the length of the repair exceeds maximum necessary time and the determination of the unrepairability of the merchandise by a report that is prepared either by a service station or the seller or a dealer or an agency or a representation office or the importer or the manufacturer, in this order, if there are no service stations.
6. Faults that are results of misuse according to the user's guide of the merchandise are not covered by the warranty.
7. Ministry of Science Industry and Technology, The Protection of the Consumer and Competition General Directorate can be referred to whenever a problem concerning the warranty document comes up.
8. Earth clamp and electrode holder kits are not under warranty.

GeKaMac®

Gedik Welding Machines

Warranty Document

MACHINE INFORMATION

Brand : GeKaMac[®]

Model :

Serial Number :

CUSTOMER INFORMATION

Company Name :

Authorized Person :

Telephone :

Company Address :

City/Country.....

E-Mail :..... @.....

Signature /Cachet :

SERVICE INFORMATION

Authorized Service :

Service Staff :

Installation Date :/...../.....

Warranty Starting Date :

Warranty Expiration Date :

Signature /Cachet :

GeKaMac[®]

Gedik Welding Machines

Warranty Document

MACHINE INFORMATION

Brand : GeKaMac[®]

Model :

Serial Number :

CUSTOMER INFORMATION

Company Name :

Authorized Person :

Telephone :

Company Address :

City/Country.....

E-Mail :..... @.....

Signature /Cachet :

SERVICE INFORMATION

Authorized Service :

Service Staff :

Installation Date :/...../.....

Warranty Starting Date :

Warranty Expiration Date :

Signature /Cachet :

GeKaMac[®]

Power ARC LT Series



GeKaMac®



Gedik Welding

Ankara Caddesi No: 306 Şeyhli Pendik, İstanbul / Türkiye

T +90 216 378 50 00 F + 90 216 378 20 44

gedik@gedikwelding.com.tr

www.gedikwelding.com